

保护特性: aR/gR

500-1250V / 10-1800A

尺寸: 00C 00 0 1
2 3 4a 4



额定电压 500-1250V AC(500V,660V,690V,1000V,1250V)

aR 短路保护

gR 全范围保护(过载保护和短路保护)

符合 IEC60269.4 标准和 GB13539.4 标准

产品采用 99.999%的纯银熔体, 高强度瓷管, 接触面镀银

尺寸符合 DIN43620 的要求, 可与国内外隔离开关配套使用

可用于保护二极管、晶闸管、可控硅整流器、GTO、IGBT、变频器、软起动器等半导体器件和设备。主要应用于直流电机传动、中频电源、电化学、不间断电源、整流桥内部的短路保护

当用户需要采集信号时, 可以在熔断器加装(一常开一常闭)微动开关, 订货时需注明

型号说明



外形尺寸

BSH 系列 00C、00、0、1、2、3 和 4a

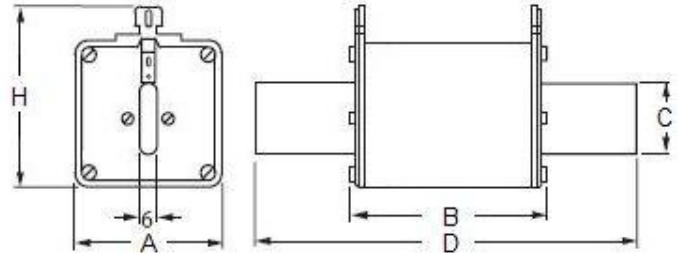

型号	A	B	C	D	H
BSH00C	21	49	15	78	52
BSH00	30	49	15	78	59
BSH0	30	68	15	125	59
BSH1	48	68	20	135	60
BSH2	58	68	27	150	68
BSH3	68	68	33	150	85
BSH4a	102	90	50	201	115

BSH4

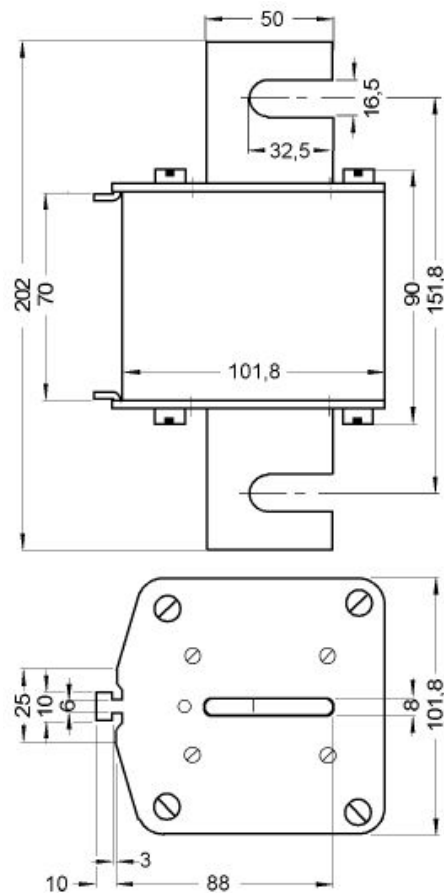

500V,660V 和 690V 技术参数

型号	额定电流 (A)	额定电压 (V)	分断能力 (kA)	保护特性	弧前 I ² t (A ² s)	熔断 I ² t (A ² s)	功耗 (W)	
BSH00C	10	500	120	aR/gR ≤125A aR >125A	3.5	25	3	
	16				7.0	45	5	
	20				11	75	7	
	25				19	130	9	
	32				40	270	10	
	40	660	100		69	460	12	
	50				115	770	15	
	63				215	1450	16	
	80	690	80		380	2550	19	
	100				690	4650	25	
	125				1200	8500	28	
	160				2300	16000	32	
	200	500	80		4200	28000	37	
	250				7750	51500	42	
315	12000			80500	52			
BSH00	20	500	120	aR/gR ≤200A aR >200A	11	75	7	
	25				19	130	9	
	32				40	270	10	
	40				69	460	12	
	50				115	770	15	
	63	660	100		215	1450	16	
	80				380	2550	19	
	100				690	4650	25	
	125	690	100		1200	8500	28	
	160				2300	16000	32	
	200				4200	28000	37	
	250				7750	51500	42	
	315	500	100		12000	80500	52	
	BSH0	32	500		120	aR/gR ≤250A aR >250A	32	170
40		53		280			9.5	
50		87		470			10	
63		130		700			11	
80		180		970			12.5	
100		660	120	390			2080	15
125				720			3890	18
160				1550			8320	22
200		690	120	2950			15900	27
250				5560			29900	33
315				11600			62300	40

500V,660V 和 690V 技术参数

型号	额定电流 (A)	额定电压 (V)	分断能力 (kA)	保护特性	弧前 I ² t (A ² s)	熔断 I ² t (A ² s)	功耗 (W)
BSH1	63	500	120	aR/gR ≤350A	130	700	18
	80				220	1170	22
	100				290	1570	23
	125				630	3320	26
	160	660		aR >350A	1170	6270	29
	200				2470	13300	33
	250	690		4670	25100	37	
	315			9570	51400	42	
	350			13400	72300	44	
	400			19500	10500	48	
BSH2	160	500	120	aR/gR ≤500A	960	5150	38
	200				1700	9210	42
	250				3480	18700	46
	315				6860	36900	54
	350	660		aR >500A	9570	51400	58
	400				13400	72300	63
	450	690		21000	113000	69	
	500			27400	147000	73	
	550			38300	206000	78	
	630			58700	315000	85	
700	78100	420000	87				
BSH3	315	500	120	aR/gR ≤800A	5250	28200	57
	350				7560	40600	58
	400				10500	56500	65
	450				15700	84300	70
	500	660		aR >800A	22200	119000	75
	560				30200	163000	80
	630	690		42000	226000	89	
	700			61700	332000	100	
	800			88900	478000	112	
	900			123900	666000	125	
1000	178400	959000	140				
BSH4a BSH4	1100	500	120	aR	195000	8750000	160
	1250	660			220000	1100000	185
	1400				300000	1600000	200
	1500	690			360000	2100000	210
	1600				450000	2400000	230
	1800				530000	2800000	260

型号示例: BSH3-630A/690V AC gR

690V 特性曲线

BSH00C

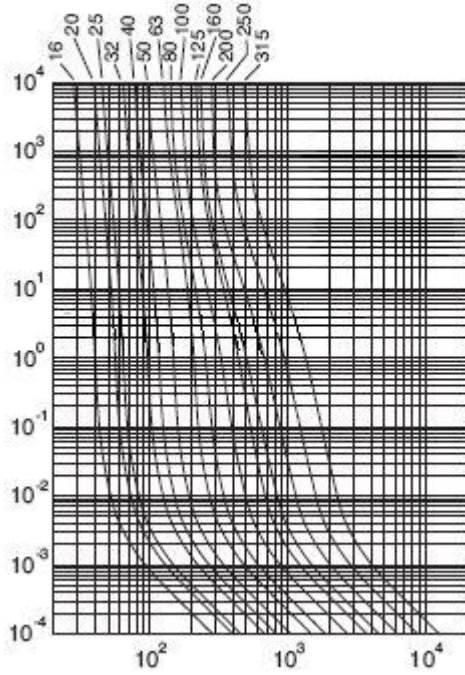

BSH00

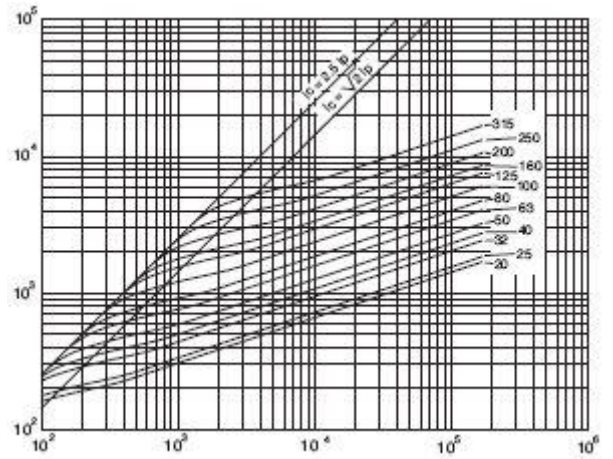
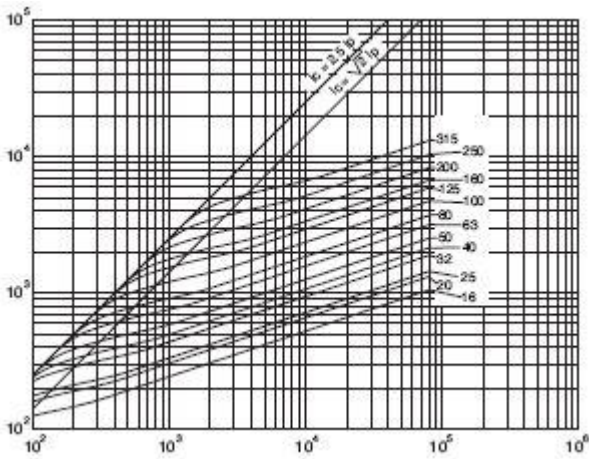
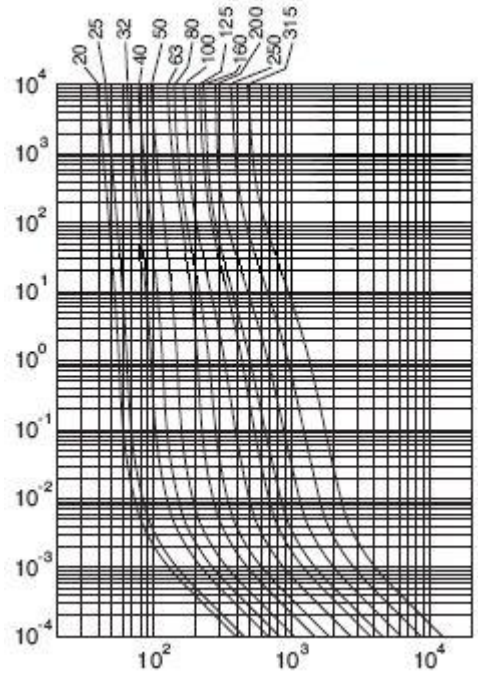

690V 特性曲线

BSH0

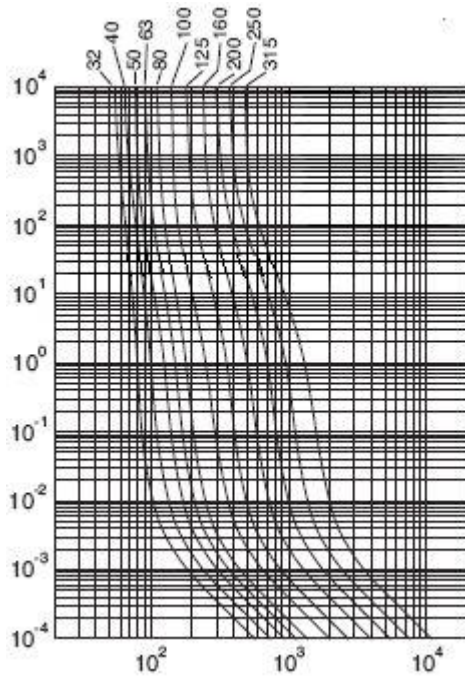

BSH1

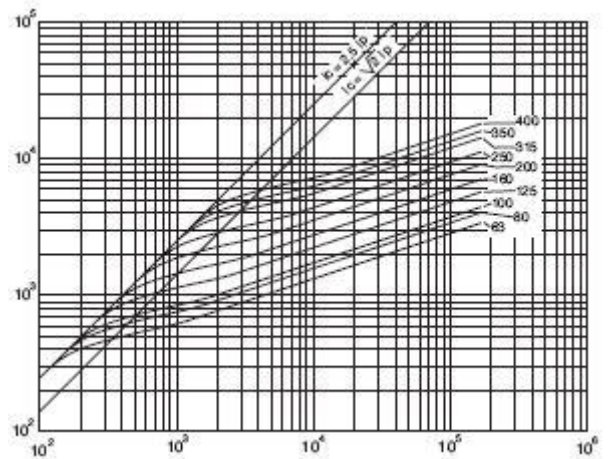
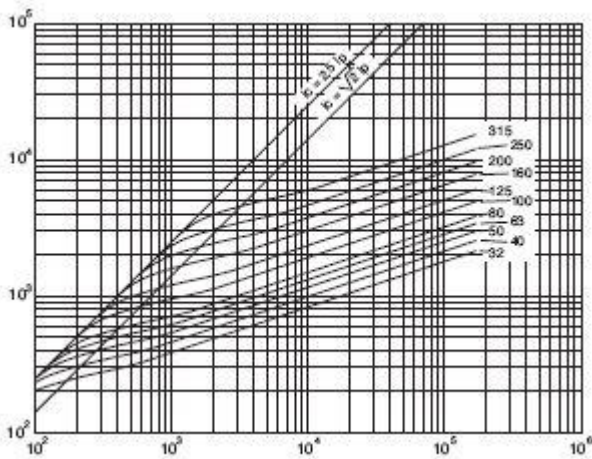
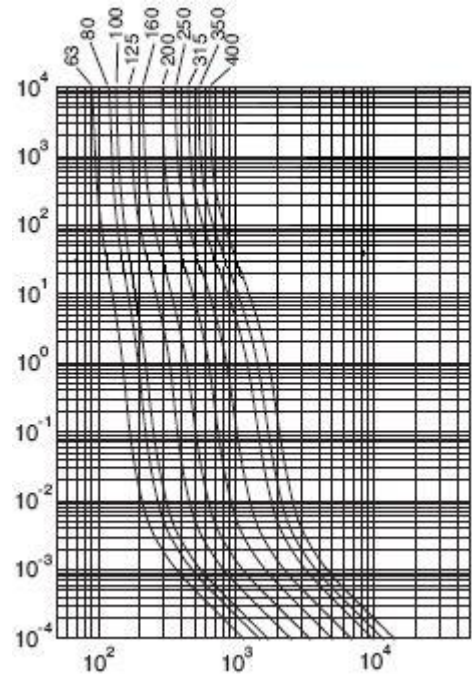

690V 特性曲线

BSH2

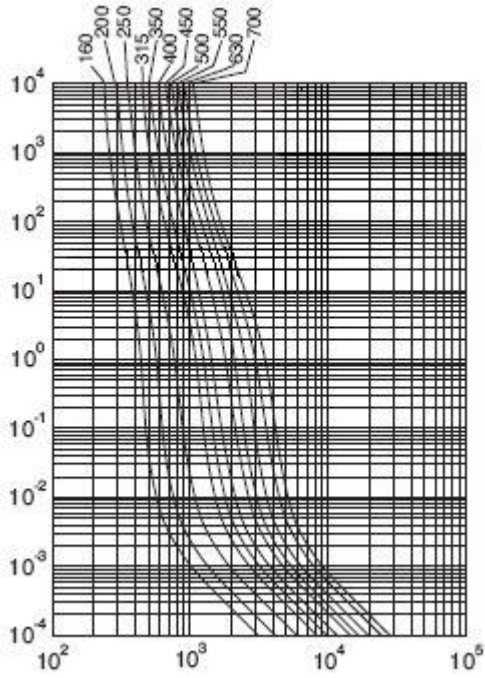

BSH3

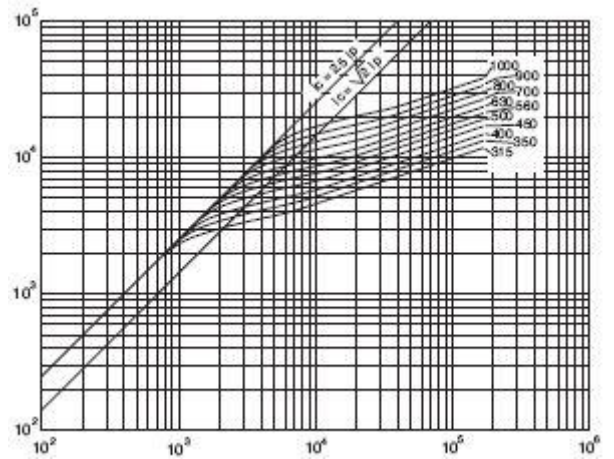
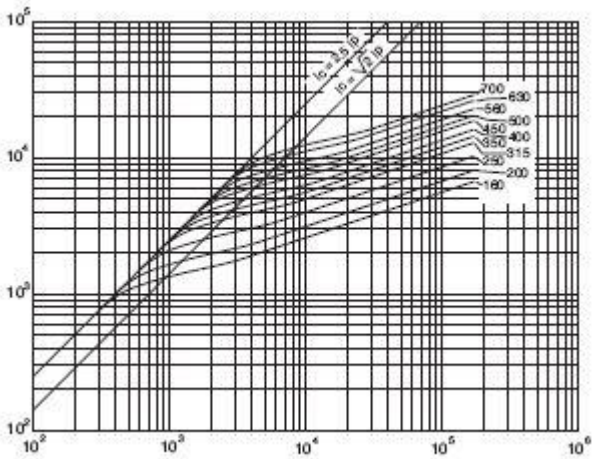
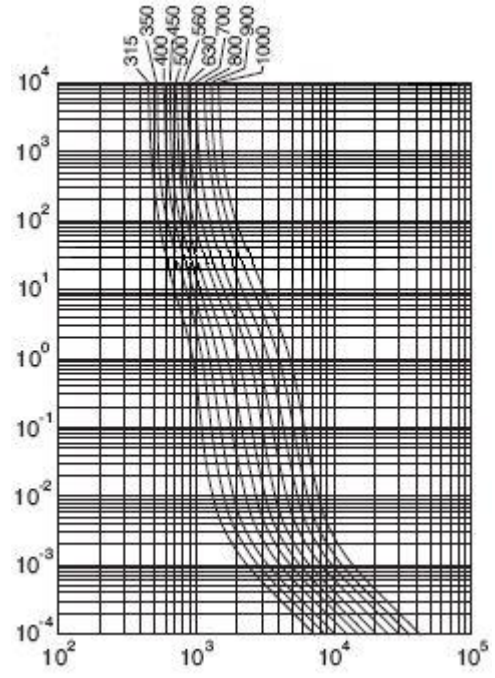

1000V 和 1250V 技术参数

型号	额定电流 (A)	额定电压 (V)	分断能力 (kA)	保护特性	弧前 I ² t (A ² s)	熔断 I ² t (A ² s)	功耗 (W)
BSH00	20	1000	100	aR	15	110	8
	25				28	210	9
	32				70	390	11
	40				105	760	13
	50				215	1550	14
	63				380	2750	16
	80				815	5900	18
	100				1550	11500	21
	125				3000	22000	23
	160				6250	45000	26
	200	900	100	aR	12000	86500	31
	225				18000	115000	33
BSH1	63	1000	100	aR	130	820	15
	80				200	1450	18
	100				390	2700	22
	125				585	4100	23
	160				1250	8300	35
	200	1250	100	aR	2450	17500	40
	250				4600	31000	45
	315				7300	52000	55
	350				12000	73000	62
BSH2	160	1000	100	aR	1450	8000	36
	200				2500	18000	42
	250				4700	30000	48
	315				7580	41500	51
	350				8000	47000	55
	400	1250	100	aR	13000	79000	66
	450				16000	120000	72
	500				24000	160000	77
	500				24000	160000	77
BSH3	315	1000	100	aR	8100	48500	78
	350				82000	49000	85
	400				12900	78000	88
	450				13500	85000	91
	500				15060	99000	97
	560	1250	100	aR	21000	148000	110
	630				34000	255000	114
	700				46000	320000	120
	800				72000	490000	125
BSH4a BSH4	900	1000	100	aR	178400	875000	140
	1000				185000	959000	150
	1100				195000	1050000	160
	1250	1250	100	aR	220000	1100000	185
	1400				300000	1600000	200

型号示例: BSH2-500A/1250V AC aR

1250V 特性曲线

BSH00

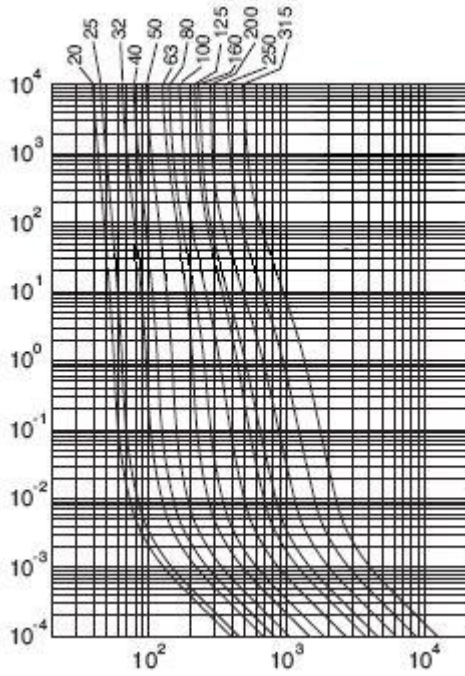

BSH1

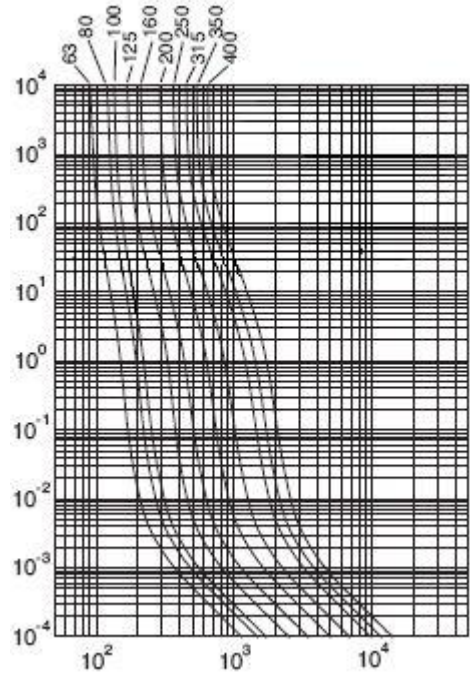

BSH2

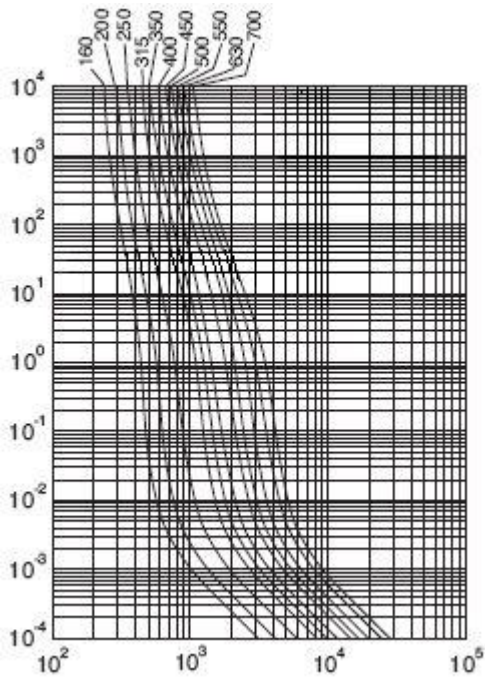

BSH3

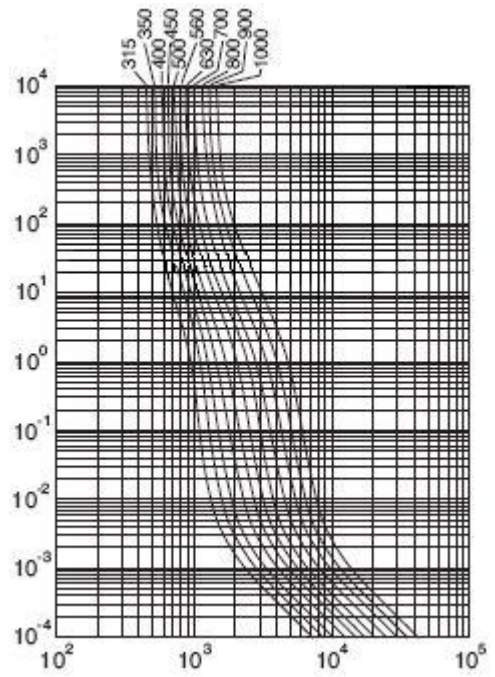

刀型配套底座

额定电压: 1250V

固定式安装

符合 GB13539 标准



技术参数

型号	额定电压(V)	额定电流(A)	配套熔断器
BCH00	1000	160	BSH00C、BSH00
BCH1	1250	250	BSH0、BSH1
BCH2	1250	400	BSH2
BCH3	1250	630	BSH3
BCH4	1250	1250	BSH4

NH4a 熔断器与隔离开关配套使用

外形尺寸

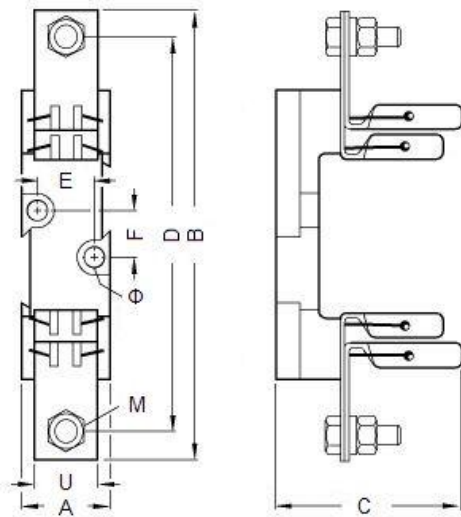

型号	A	B	C	D	E	F	U	Φ	M
BCH00	30	120	60	100	--	25	25	Φ7	M8
BCH1	60	200	82	175	30	25	25	Φ11	M10
BCH2	60	233	98	200	30	25	30	Φ11	M10
BCH3	60	243	105	210	30	25	40	Φ11	M12
BCH4	100	304	144	260	45	30	45	Φ	M12

BSH00C,BSH00 系列可替代以下进口型号(690V AC)						
博悦公司型号	BUSSMANN	FERRAZ	SIEMENS	JEAN MULLER	SIBA	EFEN
BSH00C-10A/690V	170M1558			M000uf2/10A		
BSH00C-16A/690V	170M1559	6,9gRB000PV016	3NE1813-0	M000uf2/16A		35024.0180
BSH00C-20A/690V	170M1560	6,9gRB000PV020	3NE1814-0	M000uf2/20A	2047720-20	35024.0170
BSH00C-25A/690V	170M1561	6,9gRB000PV025	3NE1815-0	M000uf2/25A	2047720-25	35024.0190
BSH00C-32A/690V	170M1562	6,9gRB000PV032		M000uf2/32A		35200.0040
BSH00C-40A/690V	170M1563	6,9gRB000PV040	3NE1802-0	M000uf2/40A	2047720-40	35024.0020
BSH00C-50A/690V	170M1564	6,9gRB000PV050	3NE1817-0	M000uf2/50A	2047720-50	35024.0030
BSH00C-63A/690V	170M1565	6,9gRB000PV063	3NE1818-0	M000uf2/63A	2047720-63	35024.0040
BSH00-80A/690V	170M1566	6,9gRB00PV0080	3NE1820-0	M00uf2/80A	2020920-80	35024.0050
BSH00-100A/690V	170M1567	6,9gRB00PV0100	3NE1021-0	M00uf2/100A	2020920-100	35024.0060
BSH00-125A/690V	170M1568	6,9gRB00PV0125	3NE1022-0	M00uf2/125A	2020920-125	35024.0070
BSH00-160A/690V	170M1569	6,9gRB00PV0160		M00uf2/160A	2020920-160	35024.0080
BSH00-200A/690V	170M1570	6,9gRB00PV0200				
BSH00-250A/690V	170M1571	6,9URD00PV0250				
BSH00-315A/690V	170M1572	5URD00PV0315				

BSH1 系列可替代以下进口型号(690V AC)						
博悦公司型号	BUSSMANN	FERRAZ	SIEMENS	JEAN MULLER	SIBA	EFEN
BSH1-35A/690V				M1uf2/35A/690V		35040.0010
BSH1-40A/690V	170M3808			M1uf2/40A/690V	2021120-40	
BSH1-50A/690V	170M3809			M1uf2/50A/690V	2021120-50	35040.0020
BSH1-63A/690V	170M3810	6,9gRB1PV0063		M1uf2/63A/690V	2021120-63	35040.0030
BSH1-80A/690V	170M3811	6,9gRB1PV0080		M1uf2/80A/690V	2021120-80	35040.0040
BSH1-100A/690V	170M3812	6,9gRB1PV0100		M1uf2/100A/690V	2021120-100	35040.0050
BSH1-125A/690V	170M3813	6,9gRB1PV0125		M1uf2/125A/690V	2021120-125	35040.0060
BSH1-160A/690V	170M3814	6,9gRB1PV0160	3NE1224-0	M1uf2/160A/690V	2021120-160	35040.0070
BSH1-200A/690V	170M3815	6,9gRB1PV0200	3NE1225-0	M1uf2/200A/690V	2021120-200	35040.0080
BSH1-250A/690V	170M3816	6,9gRB1PV0250	3NE1227-0	M1uf2/250A/690V	2021120-250	35040.0100
BSH1-315A/690V	170M3817	6,9gRB1PV0315			2021120-315	
BSH1-350A/690V	170M3818	6,9gRB1PV0350				
BSH1-400A/690V	170M3819	6,9URD1PV0400				

BSH2 系列可替代以下进口型号(690V AC)

博悦公司型号	BUSSMANN	FERRAZ	SIEMENS	JEAN MULLER	SIBA	EFEN
BSH2-125A/690V				M2uf2/125A/690V		35058.0030
BSH2-160A/690V		6,9gRB2PV0160		M2uf2/160A/690V	2021220-160	35058.0040
BSH2-200A/690V		6,9gRB2PV0200		M2uf2/200A/690V	2021220-200	35058.0050
BSH2-250A/690V		6,9gRB2PV0250		M2uf2/250A/690V	2021220-250	35058.0070
BSH2-315A/690V		6,9gRB2PV0315	3NE1230-0	M2uf2/315A/690V	2021220-315	35058.0090
BSH2-400A/690V	170M5808	6,9gRB2PV0400	3NE1332-0	M2uf2/400A/690V	2021220-400	35058.0110
BSH2-450A/690V	170M5809	6,9gRB2PV0450	3NE1333-0		2021220-450	
BSH2-500A/690V	170M5810	6,9gRB2PV0500	3NE1334-0			
BSH2-550A/690V	170M5811	6,9URD2PV0550	3NE1435-0			
BSH2-630A/690V	170M5812	6,9URD2PV0630	3NE1436-0			
BSH2-700A/690V	170M5813	6,9URD2PV0700				

BSH3 系列可替代以下进口型号(690V AC)

博悦公司型号	BUSSMANN	FERRAZ	SIEMENS	JEAN MULLER	SIBA	EFEN
BSH3-250A/690V				M3uf2/250A/690V		
BSH3-315A/690V		6,9gRB3PV0315		M3uf2/315A/690V	2021320-315	35079.0010
BSH3-350A/690V		6,9gRB3PV0350		M3uf2/350A/690V	2021320-350	35079.0020
BSH3-400A/690V		6,9gRB3PV0400		M3uf2/400A/690V	2021320-400	35079.0030
BSH3-450A/690V		6,9gRB3PV0450		M3uf2/450A/690V	2021320-450	
BSH3-500A/690V	170M6808	6,9gRB3PV0500		M3uf2/500A/690V	2021320-500	35079.0050
BSH3-550A/690V	170M6809	6,9gRB3PV0550	3NE1435-0		2021320-550	
BSH3-630A/690V	170M6810	6,9gRB3PV0630	3NE1436-0	M3uf2/630A/690V	2021320-630	35079.0060
BSH3-700A/690V	170M6811	6,9gRB3PV0700	3NE1437-0		2021320-710	
BSH3-800A/690V	170M6812	6,9gRB3PV0850	3NE1438-0			
BSH3-900A/690V	170M6813	6,9URD3PV0900				
BSH3-1000A/690V	170M6814	6,9URD3PV1000				

BSH00 系列可替代以下进口型号(1000V AC)

博悦公司型号	BUSSMANN	FERRAZ	SIEMENS	JEAN MULLER	SIBA	EFEN
BSH00-10A/1000V	170M1558					
BSH00-16A/1000V	170M1559					
BSH00-20A/1000V	170M2673					
BSH00-25A/1000V	170M2674					
BSH00-32A/1000V	170M2675					
BSH00-35A/1000V	170M2676					
BSH00-40A/1000V	170M2677					
BSH00-50A/1000V	170M2678					
BSH00-63A/1000V	170M2679					
BSH00-80A/1000V	170M2680					
BSH00-100A/1000V	170M2681					
BSH00-125A/1000V	170M2682					
BSH00-160A/1000V	170M2683					
BSH00-200A/1000V	170M2684					